

Series 7000

Zahm New Style Air Tester w/Dial Thermometer

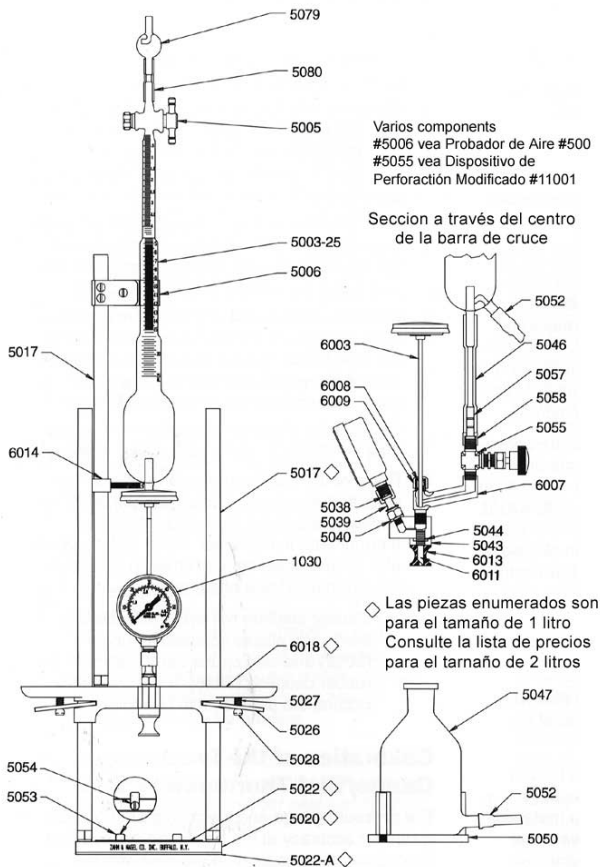

这是一套用于饮料包装后顶部剩余空气含量的测量装置.它适用于各种不同类型的包装容器,如玻璃瓶.PET瓶和和易拉罐等... 这套装置可根据气体压力和温度的关系对照检测图,自动测量出各种不同类型的包装物(如1升及2升瓶和易拉罐等...)中CO₂的含量. 并且测量范围涵盖酒精类或非酒精类饮料. 它使用的是双尺度压力表(0-60 psi & 0-4.2kg/cm²)和面盘为2"的可换算型温度计(25/125°F & -5/55°C). 这套装置同时配备了一个100cc的量管,能监测高达25cc的产品顶空空气含量.

7001	Zahm New Style Air Tester W/Dial Thermometer Complete Instrument - 1 Litre	5026	Lock Plate (2 Req'd)
7002	Zahm New Style Air Tester W/Dial Thermometer Complete Instrument - 2 Litre	5027	Lock Spring (2 Req'd)
6003	Dial Thermometer 2" Dual Scale (25/125 F. & -5/55 C.) 8" Long Stem-Adjustable	5038	Gauge Gasket
6007	Dial Thermometer Adapter	5028	Lock Screw (2 Req'd)
6008	Adapter "O" Ring	5038	Gauge Gasket
6009	Adapter Nut	5039	Gauge Adapter
6011	Piercing Needle .703 OAL of Piercing Point	5040	Adapter Gasket
6013	Rubber Seal	5043	Packing Nut
6014	Stop Pin Collar W/Pin	5044	Nut Gasket
6018	Cross Bar - 1 Litre Size	5046	Rubber Coupling
5003-25	Burette W/Teflon Stopcock (0-25ml) O-100ml Capacity	5047	Level Bottle
5005	Replacment Stopcock for Burette	5050	Level Bottle Stand
5006	Burette Clamp Complete	5052	Connection Tubing
5017	Guide Rod (2 Req'd)	5053	Can Stop (2 Req'd)
5017	Guide Rod / Support Rod for Burette(1 Req'd)	5054	Can Stop Screw (2 Req'd)
5020	Base 1 - Litre Size	5055	Whitey Valve
5022	Base Pad (Top) 1 Litre Size	5057	Hose Nipple
5022-A	Base Pad (Bottom) 1 Litre Size	5058	Nipple Nut
		5079	Caustic Trap
		5080	Plastic Coupling
		1030	Pressure Gauge (0-60psi & 0-4.2kg/cm ²) 1/8 Npt Lower Male Connection

For more information, please contact :

BQSL Japan Co., Ltd.

5-11-8-102 Okada, Atsugi-shi, Kanagawa, 243-0021 JAPAN

Tel / Fax: +81-46-230-0417

e-mail: mail@bqsl.co.jp;bqslgz@126.com